

Design Standards

Centennial Village – A Planned Unit Development A Mixed Use Walkable Lifestyle Community

Town of Munster, Indiana
A Supplement to Chapter 26: Land Development Code



**Design Standards
Centennial Village Planned Unit Development**

Table of Contents

Section 1: Purpose & Intent
Section 2: Uses
Section 3: Setback & Height Requirements
Section 4: Building Materials and Architectural Design Standards
Section 5: Building Design Elements
Section 6: Site Circulation – Vehicular & Service
Section 7: Site Circulation – Pedestrian
Section 8: Parking – Site and Under Building
Section 9: Site Lighting
Section 10: Site Landscaping & Common Areas
Section 11: Signage
Section 12: Refuse & Recycling Management
Section 13: Screening of Loading & Service Areas
Section 14: Site Furniture, Fixtures & Equipment
Section 15: Utility Service
Section 16: Storm Water Management
Section 17: Subdivision of Land and Site Development Approval

Appendices:

- 1: Centennial Village ALTA Survey & Legal Description
- 2: Preliminary Development Plan
- 3: Development Plan Set including Preliminary Landscaping Plan
- 4: Project Implementation Phasing Plan

Section 1: Purpose & Intent

The purpose of the Centennial Village Development is to provide the Town of Munster with a sustainable, mixed use, Walkable Lifestyle Community adjacent to the key regional thoroughfares of Calumet Avenue and 45th Street. The Centennial Village PUD is a partnership with the Town of Munster to combine the former Munster Steel redevelopment site with certain land areas of the Town owned Centennial Park to create a landmark development neighborhood. Additionally, the Centennial Village PUD will provide the Town of Munster the necessary land area to facilitate design and construction of the Calumet Avenue and 45th Street public infrastructure realignment improvements and underpass crossings of the CN Railroad line.

Centennial Village will include commercial, office, residential, recreational and entertainment land uses. The Centennial Village PUD is intended to support high quality development with the flexibility to adapt to the unique conditions of the site, the proposed Town public roadway infrastructure improvements, market demands and phasing of development implementation plan. The Centennial Village Development Plan has been created to meet the development goals of Town of Munster's 2010 Comprehensive Master Plan which calls for redeveloping the former Munster Steel site, improving Clay Hole Lake as a major public open space and to integrate the Centennial Village development with the existing Centennial Park and Pennsy Greenway Trail.

The mixed land uses and development density proposed within the Centennial Village PUD is essential to meet the development goals of the Town of Munster as outlined in the Development Agreement between the Town and the Centennial Village developer. The mixed use development plan is required to establish the level of commercial vitality and economic return to the Town of Munster in Tax Increment to support the approved TIF Bonds that have been granted to the project. The treatment of building design, parking, landscaping, site improvements and pedestrian spaces as outlined in the Centennial Village PUD Design Standards is essential to creating the pedestrian oriented environment for the Centennial Village walkable lifestyle community.

The Centennial Village PUD Design Standards are intended to insure the proper development of the project site to achieve the economic return goals of the Town of Munster, to improve the quality of life for existing Munster residents, to add significant architectural buildings and development areas to the Munster business landscape and to attract new businesses and residents to the Munster Community.



Section 2: Uses

The Centennial Village PUD shall permit the following uses within the development plan area:

2.1 Permitted Uses

1. Those permitted uses contained within the Town of Munster C-2 Zoning District excepting those further defined as Prohibited Uses in this Section.
2. Retail & Service Uses
 - a. Art Galleries
 - b. Bakeries
 - c. Banks & Financial Institutions
 - d. Barber & Beauty Shops
 - e. Beer, Wine & Spirits Shops – 1 Allowed within Development
 - f. Book Stores
 - g. Computer Sales & Service
 - h. Communication Equipment Sales & Service
 - i. Custom Clothing and Apparel Stores
 - j. Decorating Shops
 - k. Department Stores
 - l. Electrical and Household Appliance stores
 - m. Financial Services
 - n. Fitness Spas and Clubs
 - o. Florist Shops
 - p. Garden Supply Stores
 - q. General Retail Stores
 - r. Grocery Stores
 - s. Hardware Stores
 - t. Optical Shops
 - u. Personal Care Shops
 - v. Household Furniture, Furnishings & Appliances
 - w. Jewelry Stores
 - x. Music Shops
 - y. Photography Studios
 - z. Paint & Wallpaper Stores
 - aa. Pet Supply & Care Establishments
 - bb. Shoe Sales and Service Shops
 - cc. Sporting Goods Stores
 - dd. Tailor Shops
 - ee. Travel Service Stores
 - ff. Toy Stores
3. Recreation & Entertainment
 - a. Theaters
 - b. Community Centers
 - c. Public Outdoor Recreation

4. Hospitality
 - a. Hotels
 - b. Restaurants
5. Education
 - a. Schools such as those for teaching performance art and business vocations
 - b. K-12 academic enhancement schools
6. Offices
 - a. Business
 - b. Medical
 - c. Professional & Personal Services
7. Residential
 - a. Multi-family Dwellings
 - b. Multi-family Senior Living Facilities
8. Accessory Uses
 - a. Drive Thru Service to Customers of a Business will be permitted only by review and action by the Town of Munster Board of Zoning Appeals.

2.2 Prohibited Uses

The Centennial Village PUD shall prohibit the following uses within the development plan area:

1. Any use which emits an obnoxious odor, fumes or sound which can be heard or smelled outside of any building in the Centennial Village Area.
2. Any operation primarily used as a warehouse operation, manufacturing refining, smelting, agricultural, industrial, or mining operation.
3. Food Catering Establishments operating as the Primary Business
4. Pawn Shop, Flea Market, Salvage Store or Auction House
5. Manufactured Home Park, Trailer Court, labor Camp, Junk Yard or Stockyard
6. Mortuary or Funeral Home
7. Adult Use Establishments as defined and regulated in the Town Municipal Code
8. Tattoo Parlor & Piercings operating as the Primary Business
9. Any Unlawful or Illegal Purpose
10. Any Use that is a Public or Private Nuisance
11. Automotive Vehicle Sales
12. Automotive Retail
13. Storage Facilities where storage is the Primary Business
14. Tobacco Stores
15. Any Business dealing with Guns and Ammunition
16. All "Prohibited Uses" defined and listed in the Defined Terms, pages 8, 9 & 10 of the Centennial Park Development, Development Agreement dated September 5, 2013

Section 3 – Setback & Height Requirements

The Architectural Style proposed for the Centennial Village Lifestyle Community is modeled after a Neo-Traditional Urban Design promoting buildings placed near the street in mixed use, multi-story buildings. The public roadway right of ways serving the Centennial Village PUD include Calumet Avenue adjacent to the west side of the site and 45th Street adjacent to the north side of the southerly PUD parcel and adjacent to the south side of the northerly PUD parcel.

The Centennial Village PUD may be platted and subdivided into individual lots for each proposed building pad identified in the Development Plan. All pedestrian and vehicular circulation routes within the development parcel boundary shall serve all the subdivision lots and shall be privately owned and maintained. All subdivided lots shall be provided with pedestrian and vehicular circulation routes platted with access easements, cross access easements and cross parking easements to achieve the urban Neo-Traditional design objective.

The following is a listing of the proposed Development Plan lots with the associated Setback and Building Height Requirements:

Building Lot	Building Use Description	No. of Floors (Stories)	Maximum Building Height (ft)	Front Yard Building Setback @ Main Entry (ft)	Side Yard Building Setback (ft)	Rear Yard Building Setback (ft)
A	Retail - Anchor	1	35	30	5	5
B	Retail – Multi Tenant	1	25	5	5	5
C	Retail – Multi Tenant	1	25	5	5	5
D	Retail – Multi Tenant	1	25	5	5	5
E	Hotel	4	50	5	5	5
F	Retail – Single Tenant	1	25	5	5	5
G	Retail – Multi Tenant 1 st Floor, Residential 2 nd to 4 th Floor	4	65	5	5	5
H	Retail – Multi Tenant 1 st Floor, Residential 2 nd to 4 th Floor	4	65	5	5	5
I	Retail – Single Tenant	1	25	5	5	5
J	Retail – Multi Tenant 1 st Floor, Residential 2 nd to 4 th Floor	4	65	5	5	5
K	Retail – Multi Tenant 1 st Floor, Residential 2 nd to 4 th Floor	4	65	5	5	5
L	Residential - Multifamily	3	55	5	5	5
M	Residential - Multifamily	3	55	5	5	5
N	Retail - Anchor	1	35	5	5	5
O	Retail – Single Tenant	1	25	5	5	5

Building Lot A is located on the northeast corner of Calumet Avenue and 45th Street. Its main entry is proposed to front either 45th Street or Calumet Avenue and therefore has 2 Front Yards.

Buildings on Lot B, C, D, and E are adjacent to Calumet Avenue and Buildings B, F and I are adjacent to 45th Street. The main entries to Buildings B, C, D, E, F & I all are proposed to face inward to the development as depicted on the Development Plan and as such their front yard is considered with respect to the lot line closest and across from the main entry to each respective building. The lot line adjacent to the Calumet Avenue and 45th Street is the rear yard or side yard lot line as depicted on the Development Plan.

Building Height is defined as the vertical distance from the average elevation of the adjoining ground level or the established finish floor elevation, whichever is lower to:

1. The highest point of the cornice or parapet wall of a flat roof;
2. The deck line of a mansard roof;
3. A point directly above the highest wall of a shed roof ;
4. The uppermost point of a round or other arch type roof;
5. The mean distance from the eave line to the ridge or peak of the highest point on a pitched or gabled, hipped and gambrel styled roof

The Pensey Greenway Pedestrian Path, Sidewalks and Parking areas are permitted to be located within the designated building setbacks. The Pensey Greenway Pedestrian Path and Sidewalks shall be permitted to be placed running longitudinally over property lines so part of the path or sidewalk is located partially on public right of way and within the setback area of the development.

Section 4: Building Materials and Architectural Design Standards

Building Materials and Architectural Design for all buildings within the Centennial Village PUD for both the Commercial and Residential development areas will follow a Neo Traditional Architectural Design Style. The Neo Traditional Architectural Design Style is a contemporary architecture that borrows historical building design elements designed and constructed using modern materials. Neo Traditional Architectural Design Style is contemporary architecture that is inspired by historic styles. Neo Traditional Buildings suggest the past, using decorative details to add a nostalgic aura to a modern-day contemporary structure design style.

Neo Traditional Architecture Design Style to be developed in the Centennial Village PUD shall utilize a variety of building materials and architectural elements. The variety of building materials will be distributed throughout the development based on a class of material as listed below:



Class 1 – Primary Exterior Building Materials / Building – 1st Floor

Allowable building materials on Class 1 Exterior Building Walls shall comprise of one or more of the following materials:

- a. Brick
- b. Natural Masonry and Architectural Cast Stone
- c. Manufactured Masonry & Stone
- d. Architectural Metal Panels
- e. Glass & Store Front Aluminum Window & Door Frames
- f. Conventional Windows and Frames

Class 1 Primary Building Materials as a total sum will comprise of a minimum of 75% of the total exterior wall surface area on Class 1 building walls. Architectural Pre-cast Wall Panels will be considered as a primary material provided that a Brick or similar Architectural Stone is precast into the panel meeting the minimum of 75% of the building wall surface area. Class 1 Building Materials as defined in this Section shall only be allowed on 1st Floor Level Exterior Walls. The First Floor Level is defined from the line created at the building wall by finish exterior ground elevation grade to the top of the wall for single story buildings and to the 2nd Level Floor line for multi-story buildings.

Class 2 – Accent Materials – 1st Floor

Allowable building materials on Class 2 Exterior Building Walls shall comprise of one or more of the following materials:

- a. Architectural Masonry Block
- b. Spandrel Glass and Opaque Panels
- c. Exterior Insulation Finishing System (EIFS)
- d. Architectural Metal Panels Accents
- e. Natural Wood Panels & Siding
- f. Manufactured Wood Panels & Siding
- g. Structural Steel

Class 2 Accent Exterior Building Materials as a total sum will comprise of a maximum of 25% of the wall surface area on Class 2 building walls. Class 2 Buildings Materials as defined in this Section shall only be allowed on 1st Floor Level Exterior Walls. The First Floor Level is defined from the line created at the building wall by finish exterior ground elevation grade to the top of the wall for single story buildings and to the 2nd Level Floor line for multi-story buildings.

Class 3 – Primary Exterior Building Materials – 2nd to 4th Floors

Allowable building materials on Class 3 Exterior Building Walls shall comprise of one or more of the following materials:

- a. Brick
- b. Natural Masonry and Architectural Cast Stone
- c. Manufactured Masonry & Stone
- d. Architectural Metal Panels
- e. Glass & Store Front Aluminum Window & Door Frames
- f. Conventional Windows and Frames including Operable Aluminum or Vinyl Clad Windows

Class 3 Primary Building Materials as a total sum will comprise of a minimum of 30% of the total exterior wall surface area on Class 3 building walls. Architectural Pre-cast Wall Panels will be considered as a primary material provided that a Brick or similar Architectural Stone is precast into the panel meeting the minimum of 30% of the building wall surface area. Class 3 Materials as defined in this Section shall only be allowed on 2nd to 4th Floor Level Exterior Walls. The 2nd to 4th Level exterior wall surface is defined from the 2nd Level Floor line to the top of the upper most floor wall for buildings with flat roofs or to the uppermost level soffit or fascia line for buildings with sloped roofs.

Class 4 – Accent Materials – 2nd to 4th Floors

Allowable building materials on Class 4 Exterior Building Walls shall comprise of one or more of the following materials:

- a. Architectural Masonry Block
- b. Spandrel Glass and Opaque Panels
- c. Exterior Insulation Finishing System (EIFS)
- d. Architectural Metal Panels Accents
- e. Natural Wood Panels & Siding
- f. Manufactured Wood Panels & Siding
- g. Aluminum Fascia and Soffit Material
- h. Structural Steel

Class 4 Accent Building Materials as a total sum will comprise of a maximum of 70% of the wall surface area on Class 4 building walls. Architectural Pre-cast Wall Panels will be considered as a primary material provided that a Brick or similar Architectural Stone is precast into the panel meeting the minimum of 70% of the building wall surface area. Class 4 Materials as defined in this Section shall only be allowed on 2nd to 4th Floor Level Exterior Walls. The 2nd to 4th Level exterior wall surface is defined from the 2nd Level Floor line to the top of the upper most floor wall for buildings with flat roofs or to the uppermost level soffit or fascia line for buildings with sloped roofs.



General Building Design Requirements

1. The color and material of Service Doors shall be coordinate with the color tones and materials of the Primary Materials and match the design of the buildings they serve. Service doors shall be permitted on Class 1 and Class 2 wall surfaces and be counted as a Class 1 Primary Material.
2. Doors, Door Frames, Window surfaces and Window Frames shall be permitted on all classes of materials and be counted in the quantity of Primary Materials.
3. Bright accent colors such as bright orange, bright yellow or fluoresent colors shall be minimized and in no case shall such coloring exceed 5% of any exterior wall area.
4. Brick or stone exteriors shall not be painted without the prior approval of the Town of Munster Plan Commission.
5. Equipment used for mechanical, processing, bulk storage tanks or equipment used for suppressing noise and odor that protrudes from a side of a building or is located on the ground adjacent to a building shall be screened from public view as much as practical with Class 1 & 3 Primary Building Materials matching the design of the building and landscaping treatments.
6. Equipment used for mechanical, processing and bulk storage tanks placed on roofs of buildings shall be screened from public view as much as practical with Class 2 & 4 Accent Building Materials matching the design of the building.
7. Pre-engineered metal and wood pole buildings are prohibited.



The distribution of Architectural Class Materials on all buildings throughout the project site is summarized in the table below:

Building Lot	Building Use Description	No. of Floors (Stories)	Building Materials on Exterior of First Floor	Building Materials on Exterior of 2nd thru 4th Floor
A	Retail – Anchor	1	Class 1 & 2	N/A
B	Retail – Multi Tenant	1	Class 1 & 2	N/A
C	Retail – Multi Tenant	1	Class 1 & 2	N/A
D	Retail – Multi Tenant	1	Class 1 & 2	N/A
E	Hotel	4	Class 1 & 2	Class 3 & 4
F	Retail – Single Tenant	1	Class 1 & 2	N/A
G	Retail – Multi Tenant 1 st Floor, Residential 2 nd to 4 th Floor	4	Class 1 & 2	Class 3 & 4
H	Retail – Multi Tenant 1 st Floor, Residential 2 nd to 4 th Floor	4	Class 1 & 2	Class 3 & 4
I	Retail – Single Tenant	1	Class 1 & 2	N/A
J	Retail – Multi Tenant 1 st Floor, Residential 2 nd to 4 th Floor	4	Class 1 & 2	Class 3 & 4
K	Retail – Multi Tenant 1 st Floor, Residential 2 nd to 4 th Floor	4	Class 1 & 2	Class 3 & 4
L	Residential – Multifamily	3	Class 1 & 2	Class 3 & 4
M	Residential – Multifamily	3	Class 1 & 2	Class 3 & 4
N	Retail – Anchor	1	Class 1 & 2	N/A
O	Retail – Single Tenant	1	Class 1 & 2	N/A

Section 5: Building Design Elements

In addition to Exterior Building Material Standards, all buildings within the Centennial Village PUD shall comply with the following Building Design Elements requirements.

1. Building facades shall provide architectural detail and character that contain windows at the ground level in areas oriented to the pedestrian activities of the development to create views into buildings with focus to building main entries. The building and pedestrian interface is a crucial part of the urban design and the design shall provide visual interest, create opportunities for pedestrian socialization and overall pedestrian safety and comfort.



2. The use and appearance of all exterior building materials within the development shall be compatible with adjacent and surrounding buildings.
3. The use and appearance of all exterior building materials used on side and rear building walls of any building shall be similar to and compatible with its front building wall.
4. All buildings shall be located such that the front doors of the building front a public street or parking areas. Any building with a building wall adjacent to a public street that does not provide for the front door to front the public street shall design the building wall adjacent to the public street with Primary Building Materials and with design features to make the adjacent wall to the public street look as if it is a main entry wall.
5. Parking Garages shall be located to the rear or interior of the site. Entrance ramps to underground parking areas shall be located near service areas of buildings and screened from public view with landscaping or other structural screening walls.
6. Main entries to buildings shall be emphasized through the use of architectural features such as covered roof overhangs, increased building heights with columns, featured roof elements, and recession or extension of the building façade or other architectural details that highlight the importance of the entrances.
7. The rear entrance to a building can be utilized as an additional primary entrance when parking areas are located in the interior of a block as is typical for a traditional urban development plan. When rear building entrances are used as an additional primary entrance, the entries should be improved to include signs, lighting, canopies, windows, landscaping and other complementary elements to create a safe and inviting access to the additional building entry.

8. All building fronts shall include a minimum of 4 architectural details following the items listed below:

- a. Cornice Architectural Details
- b. Architectural Awning including Structural Steel or Canvas Awning
- c. Parapet Wall Detailing
- d. Brick Coursing changes such as soldier coursing, row lock coursing and stack bond coursing
- e. Masonry Stone Accenting around windows, doors and roof lines
- f. Entry Feature Columns
- g. A visually pleasing, clearly articulated entry which presents the obvious entry location from the street, sidewalk and parking area.
- h. A combination of horizontal and vertical design features
- i. Contrasting but complimentary materials and colors
- j. Irregular building shapes
- k. Horizontal offsets in the entry door wall relative to the primary front façade wall
- l. Vertical offsets in the roof line of the entry door wall relative to the primary front façade wall
- m. Varying roof lines and accents



9. Multi-story buildings shall have the ground floor distinguished from the upper floors by having one or more of the following:

- a. Awnings
- b. Trellis
- c. Window Lintels
- d. Cornice Line delineating the change between the First Floor level and the 2nd Floor level
- e. Brick detailing such as quoins or corbels delineating the change between the First Floor level and the 2nd Floor level
- f. A change in Primary Building materials between the First Floor level and the 2nd Floor level

10. All buildings within the development will utilize a variety of complimentary architectural materials, design elements, colors and the use of vertical and horizontal design features in such a way so that no one building is identical or monotonous with any other building. The Neo Traditional Design Style defined for the Centennial Village project encourages the architectural, color and building material differences between buildings on all lots within the development.



Section 6: Site Circulation – Vehicular & Service

The Centennial Village Site will be provided vehicular access from public right of ways depicted in the Development Plan and specifically defined below:

1. Development Area North of 45th Street:
 - a. Full Access Entry Driveway on the north side of 45th Street approximately 500 feet west of the Calumet Avenue center line. The Full Access Entry Driveway will be controlled by a traffic control signal to be provided by the Town of Munster in the 45th Street public infrastructure project plans and coordinated with the Centennial Village development plans on the south side of 45th Street.
 - b. Right in – Right out entry drive on the east side of Calumet Avenue approximately 200-feet north of the 45th Street center line.
2. Development Area South of 45th Street:
 - a. Full Access Entry Driveway on the south side of 45th Street approximately 500 feet west of the Calumet Avenue center line. The Full Access Entry Driveway will be controlled by a traffic control signal to be provided by the Town of Munster in the 45th Street public infrastructure project plans and coordinated with the Centennial Village development plans on the north side of 45th Street.
 - b. Right in – Right out entry drive on the east side of Calumet Avenue approximately 400-feet south of the 45th Street center line.
 - c. Full Access Entry Driveway at the Centennial Drive and Calumet Avenue intersection. The Centennial Drive Entry Driveway shall be shared by the Centennial Village PUD area and the Town of Munster Centennial Park. The existing Centennial Drive Traffic Signal and intersection at Calumet Avenue will be modified by the Centennial Village PUD to accommodate the additional traffic generated by the development project.
3. The Development Plan for the development area south of 45th Street is divided into 4 development quadrants by the location of 2 main access roadways. The site is divided by a main north-south roadway and an east-west roadway. All vehicular roadways within the Centennial Village PUD shall be privately constructed, owned and maintained.
4. The main north-south thoroughfare named “Centennial Drive” will be developed to intersect with Calumet Avenue at the southwest corner of the site, extend easterly to connect with the existing Centennial Park parking lot, then extend northerly to a proposed Centennial Drive Town Center Green round about, and then further extend north to intersect with 45th Street.



5. The main east-west thorough fare named “Village Parkway” extends easterly from Calumet Avenue at the west central edge of the site into the Centennial Drive Town Center Green round about.
6. All parking areas located within each of the 4 quadrants shall be connected to both Centennial Drive and Village Parkway.
7. Centennial Drive and Village Parkway shall have 12-foot minimum vehicular travel lane widths. The minimum lane width of Centennial Drive at the Calumet Avenue and 45th Street intersections shall be 11-foot wide. Lane widths shall be measured from the center line of any lane striping to the face of curb. For conditions where there is not lane striping, the lane width shall be measured between face of curb to face of the opposite curb.
8. Minimum cross slopes perpendicular to the direction of travel shall be 2%. Minimum longitudinal slope of the curb gutter flow line shall be 0.50%.
9. The minimum pavement cross section for roadways and parking lots shall consist of 10-inches of No. 53 aggregate placed on a stable subgrade with 3-inches of H.A.C. Binder Course and 1 ½-inches of H.A.C. Surface Course. The final pavement cross section specification will be developed to accommodate the specific subgrade conditions where roadways and parking lots are placed.
10. Minimum combination curb and gutter sections widths shall be a combination of a 6-inch wide curb with a 12-inch wide gutter flag.
11. Boulevards located in the center of Centennial Drive and Village Parkway shall be bordered at the street with a 6-inch wide stand up curb.
12. Cross Access Easements and shared Public Common Space Agreements will be developed during the subdivision platting process to provide for the sharing of parking, vehicular circulation and pedestrian access among all property owners, business tenants and residents within the development.

Section 7: Site Circulation – Pedestrian

The Centennial Village PUD is located adjacent to the recreational activities within Centennial Park including the regional Pensey Greenway Trail. The Centennial Village PUD site design shall emphasize pedestrian connections with Centennial Park walkways, the Pensey Greenway Trail and future sidewalks proposed by the Town of Munster in the 45th Street and Calumet Avenue public infrastructure improvement plans.

1. The Pensey Greenway Trail will be extended from the south boundary of the Centennial Village PUD and extend along the west shore line of Clay Hole Lake to the south right of way line of the new 45th Street right of way. This trail extension will be completed by the Centennial Village PUD and will be constructed to standards matching the existing trail south of the Centennial Village PUD.
2. Pedestrian walkways adjacent to and within the Centennial Drive corridor connecting Calumet Avenue to 45th Street shall be a minimum of 10-feet wide. Pedestrian walkways adjacent to buildings within the Village Parkway corridor shall be a minimum of 10-feet wide. Pedestrian walkways adjacent to buildings in all other areas of the development shall be a minimum of 8-feet wide.
3. Where sidewalks are integral with parking area curbs within parking areas of the development, the minimum sidewalk width shall be 5-feet.
4. All sidewalks shall be constructed of Portland Cement Concrete and shall be a minimum of 4-inches in thickness for pedestrian use only areas and a minimum of 6-inches in thickness for vehicular service loadings areas and shall be placed on a minimum of 4-inches of base sand or No. 53 aggregate.
5. Pedestrian routes crossing streets and driveways within the development shall be constructed with a material contrasting with the pavement material of the street or driveway. Acceptable materials for pedestrian route street and driveway crossings shall include colored concrete, paver bricks and paver blocks.
6. All pedestrian routes crossing streets and driveways within the development will be provided with ADA Accessible Ramps meeting the design requirements of all State and Federal Accessibility Requirements.
7. Sidewalks within the development and the Calumet Avenue and 45th Street right of ways will be maintained by the Centennial Village PUD. Snow removal of sidewalks within the development and the will Calumet Avenue & 45th Street right of ways will be the responsibility of the Centennial Village PUD.
8. The Centennial Village PUD shall plat the appropriate pedestrian access easements during the site development and subdivision platting process through the Town of Munster Plan Commission.

Section 8: Parking – Site and Under Building Parking Areas

The Centennial Village PUD is an urban development plan designed to provide for shared parking for all lots within the development. All building lots within the development will be platted with Cross Access Easements and all parking lots shall be designed to be interconnected for both pedestrian and vehicular access. Off-street and on-street parking shall be provided within the development on common parking lots, along circulation roadways and in parking structures.

1. The total minimum number of parking spaces required for the Centennial Village PUD shall be calculated on the following basis:

Land Use	Minimum Required Parking
Retail – Single Tenant	3.25 parking spaces per 1,000 sf of Gross Building Floor Area
Retail – Multi-tenant	3.25 parking spaces per 1,000 sf of Gross Building Floor Area
Restaurant	1.0 space per 4 customer seats
Office Uses	4.0 parking spaces per 1,000 sf of Gross Building Floor Area
Hotel	1.05 parking spaces per number of Hotel Room Units
Residential – Multi-family	1.25 spaces per Residential Unit

Off-street parking for commercial uses shall be sufficient to provide parking for employees of all proposed uses as well as customer parking. Spaces reserved for employees may be designated by means of striping and signage. The location, quantity, signage and design standards for parking spaces for the disabled shall be designed to meet the requirements of all State and Federal Accessibility Requirements.

2. Parking Areas shall be designed to conform to the following standards:
 - a. Parking space dimensions (other than those designed for the disabled) perpendicular to the parking area drive aisles shall be a minimum of 18-feet long and 9-feet wide. Angle parking shall maintain a full 18-foot x 9-foot block within the angled parking space. Parking spaces shall be dimensioned in relation to face of curbs and walks and to the centerline of parking space striping lines.
 - b. Parking space dimensions parallel to roadways within the development shall be a minimum of 20-feet long by 8-feet wide.
 - c. Parking space dimensions for the disabled shall meet the design requirements of the Federal Americans with Disabilities Act.
 - d. Parking lots shall be constructed of Hot Asphaltic Concrete, Portland Cement Concrete or other acceptable hard surface material approved by the Town of Munster Plan Commission and meeting Town Standards.
 - e. All parking areas shall be edged with Portland Cement Concrete vertical curbs, curb and gutters and mono-thically formed curb sidewalks.
 - f. Parking areas shall be landscaped in Planting Areas as defined in the Centennial Village PUD Development Plan. The parking area Planting Areas shall be landscaped with Trees, shrubs and perennial flowers.
 - g. Parking area landscaping shall conform to an approved Landscaping Plan and to the design standards defined in the Site Landscaping – Section 10.

3. Parking Areas shall be owned, operated and maintained by the Centennial Village PUD land and building owners. The parking areas shall be kept clean and well maintained and shall conform to the following operations standards:
 - a. Striping defining parking areas, loading and service zones, stop bars, directional arrows, lane division and other pavement markings shall be clearly visible at all times. Parking area striping shall be re-painted when the parking area markings are faded and compromises safety to patrons of the development.
 - b. Failed pavement shall be properly repaired to assure safe and convenient travels within the development.
 - c. Snow removal of sidewalk, parking areas and driveways within the Centennial Village PUD shall be the responsibility of the Centennial Village PUD owners. Snow removal shall be completed during any snow event on all building lots within the development on a unified basis. Snow shall be placed on the perimeter and islands of parking areas and driveways. During heavier snow events, snow will be removed from the site and deposited at designated locations into Clay Hole Lake. The Development Plan shall identify the specific designated snow deposit areas. The design of the snow deposit areas shall be detailed and designed to accommodate the needed grading and structural loading of the snow removal equipment.
 - d. Parking areas shall be regularly cleaned of debris.

Section 9 – Site Lighting

Site lighting shall be decorative in nature and consistent with the architectural design of buildings within the development. All site lighting within the Centennial Village PUD shall adhere to the following requirements for illumination of parking areas, pedestrian walkways and roadways.

- All exterior lighting shall be designed and constructed to direct light away from adjacent properties.
- All exterior lighting shall be arranged and designed with a common light fixture type and with a variety of heights based on lighting system use. Vehicular and pedestrian level lights shall illuminate directly below or inboard of the property lines of the property such that the point source of light is not directly viewed by pedestrian or vehicular traffic in adjacent public right of ways.
- Lighting shall be designed such that there is a minimum of 0.5 foot-candles at any property line. A photometric plan inclusive of all site and building sconce lighting for each fixture shall be submitted for review by the Town of Munster at each site plan review application. Photometric lighting levels within parking, roadway and pedestrian areas shall be illuminated to a range of 3 to 10 foot candles.
- Lighting which is flashing or revolving in nature or that otherwise resembles a traffic control signal shall not be permitted in any development area where it could cause a hazard for pedestrian or vehicular traffic.
- Parking areas shall be adequately lighted for the safety of pedestrian and vehicular movements using decorative style lighting with a design style equal to the "Genesis Series" model manufactured by Sternberg Lighting. No "shoe box" style lighting shall be permitted. Parking Lot lighting shall have a maximum height to the top of the fixture of 26-feet.
- Roadway areas shall be adequately lighted for the safety of pedestrian and vehicular movements using decorative style lighting with a design style equal to the "Genesis Series" model manufactured by Sternberg Lighting. No "shoe box" style lighting shall be permitted. Roadway area lighting shall have a maximum height to the top of the fixture of 22-feet.



ESTABLISHED 1923 / EMPLOYEE OWNED
GENESIS Product Configurator

Catalog Number: 2-1912C-ARM(R2ZPM)TOPS(F)CC35HPS120MEDDBA0K Type: _____

Customer Approval: _____

Signature: _____ Date: _____

Conceptual assembly drawing, subject to Engineering verification by factory.

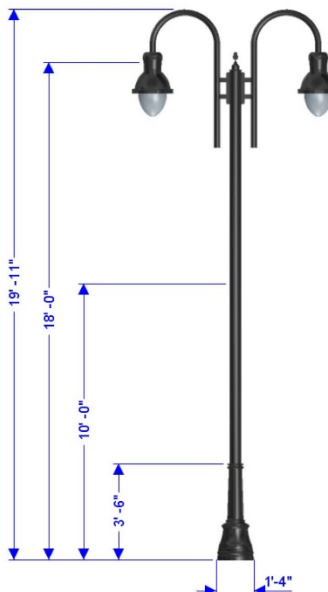

NUMBER OF ARMS: 2

ARM MOUNTED FIXTURE: 1912
The 1912 Summit series is a decorative downlight fixture consisting of a decorative cast aluminum litter, ballast housing assembly and a prismatic glass, polycarbonate or acrylic clear drop screen. Its dome housing is made of cast aluminum having 4 wide band vertical ribs matching the cap ribs in its upper section.

ARM: R2PM 12PM

POLE: 671BP5
The 1 1/2" diameter cast aluminum base and aluminum shaft shall be a one piece construction. The pole shall be U.L. or E.I.L. listed in U.S. and Canada.

POLE CAP: FCC
FINIAL CENTER CAP

LIGHT SOURCE: 35HPS120MED
Ballast - 35HPS
Voltage - 120
Socket Type - MFD

ACCESSORY: DBA
The double banner arms mount to the side of the pole and are made from heavy-wall aluminum. Banners by others.

FINISH: BK
Assembly shall be powder coated to Black Smooth finish. Prior to coating, the assembly shall be chemically cleaned and etched in a 5 stage washing system which includes alkaline cleaning, rinsing, phosphoric etching, reverse osmosis water rinsing, and non-chrome sealing to ensure corrosion resistance.

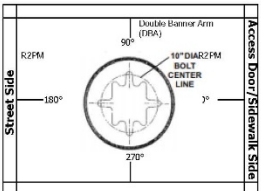

Street Side | Access Door/Sidewalk Side

Rev	Description	By	Date	Job Name

Job Location:	Drawing No.:	Drawing Title:	Drawing Date:

7. Pedestrian walkways not lighted by parking or roadway lighting shall be adequately lighted for the safety of pedestrians using decorative style lighting with a design style equal to the “Genesis Series” model manufactured by Sternberg Lighting. Pedestrian area lighting shall have a maximum height to the top of the fixture of 14-feet. Pedestrian walkways can also be illuminated using decorative wall sconce lighting matching the style of parking and roadway lighting mounted on buildings adjacent to pedestrian walkways. No “shoe box” wall mounted fixture lighting shall be permitted.
8. Decorative wall mounted or ground mounted lighting may be used on building fronts visible from streets and parking areas to illuminate building entries and highlight building architectural features.
9. Lighting Pole and Fixture locations shall be out of the way of service and pedestrian access to buildings throughout the development site.

Section 10 – Site Landscaping

Landscaping for the Centennial Village PUD shall be required in accordance with a final detailed Landscaping Plan approved by the Town of Munster Plan Commission for each building and development phase at the Site Development Plan submittal. All areas of the site not occupied by buildings, parking areas and other site improvements or paving shall be planted with trees, shrubs, hedges, perennials, annual flowers, ground cover and or grasses unless such plantings shall cause a public safety or safe sight line condition for vehicles and pedestrians. Site Landscaping within the Centennial Village PUD shall adhere to the following requirements:

1. Landscaping Design Standards and Specifications shall generally follow the requirements of Article X of Chapter 26 of the Munster Land Development Code.
2. Landscaping shall be integrated with other functional and ornamental site design elements such as pedestrian paths and walkways, site furniture, fountains, trellises, gazebos, screen walls and public art.
3. Plant suitability, maintenance and compatibility with site and construction features shall be considered in the final landscape design plans for each building lot. Plantings should be designed with repetition, structured patterns and complimentary textures and colors and should reinforce the overall character of the development. After construction, maintenance of plants and landscaping will be completed to a high standard, keeping lawns, grasses and plants regularly groomed, planted areas free from weeds and debris, and plants that have died replaced.
4. All stumps and other tree parts, litter, brush, weeds and vegetation debris shall be removed from the development and lawfully disposed. If trees and limbs are reduced to chips, they may be used as mulch in landscaped areas. Areas which are to remain as undeveloped open space shall be cleaned of all vegetation debris.
5. Landscaping of cut and fill areas for the creation of proper drainage shall be constructed with grading slopes and plant materials to prevent soil erosion.
6. Planted landscaping shall meet the following specification at the time of planting unless otherwise specified in the Landscape Plan.
 - a. Deciduous trees shall be at least a 2 ½-inch caliper and have an average 8-foot height
 - b. Evergreen trees shall be a minimum of 6-feet in height
 - c. Shrubs shall be 3-feet in height
7. Material and installation specifications for all trees, shrubs, bushes, annuals and perennials shall be specified to meet local horticultural standards and meet the local growing and climatic conditions. The materials and installation shall be appropriate for an Urban Development environment. Shrub plant selection shall be made using drought tolerant vegetation to the extent possible. Plant materials shall be nursery stock grown conforming to ANSI Z60.1. No trees planted in the development shall be topped, tipped or deformed in any way at the time of planting.

8. Within one year from the time of installation, all dead or dying plants and lawns shall be replaced in kind in the locations and specifications in accordance with the Landscape Plan.
9. Tree spacing shall be determined and identified in the Landscape Plan based on the tree species type. As a general guide to the Landscape Plan basis of design, larger maturing trees shall be planted a minimum of 30-feet on center. Smaller maturing trees shall be planted at a minimum of 20-feet on center. Larger maturing trees will generally be planted along street frontages, right of ways and on the perimeter edges of the development.
10. Refuse and recycling collection areas and other building utility service areas shall be screened with a combination of structural screen walls and landscaping designed to match the building architecture it services. The screen walls shall be a minimum of 5-feet in height with a corresponding landscaping buffer against the wall designed to grow in height to match the height of the screen wall. A mixture of hardy flowering and/or decorative evergreen and deciduous trees will be planted with bushes and shrubs in the screen wall buffer against the screen wall and with a decorative stone ground cover.
11. Larger landscape areas will be provided with irrigation systems. The following areas may be serviced with irrigation systems:
 - a. Center Green Boulevard Area between Buildings J & K
 - b. Main Sign Location at the Southeast Corner of 45th Street & Calumet Avenue
 - c. Boulevard Islands on Village Parkway
 - d. Boulevard Islands on Centennial Drive
 - e. Outdoor Plazas in the rear of Buildings G, H, J & K
 - f. Outdoor Plazas on the sides of Buildings N
12. Maintenance of all Landscaping within the Centennial Village PUD shall be completed by the Centennial Village development.
13. Acceptable for tree plantings within planting islands and parkways are set out in Table 10-13-1 and Table 10-13-2:

Table 10-13-1 Trees for Parking Lot Islands and General Landscaping		
Common Name	Scientific Name	Mature Height
Chinquapin Oak	Quercus Muehlenbergii	80-feet
Hackberry	Celtis Occidentalis	60-feet
Kentucky Coffee Tree	Gymnocladus	60-feet
Skyline Honey Locust	Gleditsia Triacanthos	60-feet
Shingle Oak	Quercus Imbarcaria	50-feet
Swamp White Oak	Quercus Bicolor	50-feet
Sour Gum	Nyssa Sylvatica	40-feet
Ironwood	Ostrya Virginiana	30-feet
Japanese Tree Lilac	Syringa Reticulata	30-feet
Blue Beech American Hornbeam	Carpinus Caroliniana	20-feet

Common Name	Scientific Name	Mature Height
Chinquapin Oak	Quercus Muehlenbergii	80-feet
Burr Oak	Quercus Macrocarpa	80-feet
American Elm	Ulmus Americana	70-feet
Hackberry	Celtis Occidentalis	60-feet
Kentucky Coffee Tree	Gymnocladus	60-feet
American Linden	Tilia Americana	60-feet
Skyline Honey Locust	Gleditsia Triacanthos	60-feet
Shingle Oak	Quercus Imbarcaria	50-feet
Hills Oak	Quercus Ellipsoidallis	50-feet
Scarlet Oak	Quercus Coccinea	50-feet
Sugar Maple	Acer Saccharum	50-feet
Swamp White Oak	Quercus Bicolor	50-feet
Sour Gum	Nyssa Sylvatica	40-feet
Littleleaf Linden	Tilia Cordata	40-feet
Ironwood	Ostrya Virginiana	30-feet
Japanese Tree Lilac	Syringa Retuculate	20-feet
Blue Beech American Hornbeam	Carpinus Caroliniana	20-feet
Serviceberry	Amelanchier Sp.	20-feet
Nannyberry Viburnum	Viburnum Lentago	18-feet

14. Acceptable for shrub plantings within planting islands and general landscape areas are set out in Table 10-14-1 and Table 10-14-2:

Common Name	Scientific Name
Spicebush	Lindera Benzoin
Downy Serviceberry	Amerlanchier Arborea
Dommon Chokecherry	Prunus Viriniana
Forsythia	Forsythia Spp.
Lilac	Syringa Spp.
Viburnums	Viburnum Spp.
Currant Gooseberry	Ribes Spp.
Weigla	Weigela Spp.
Smoketree	Cotinus Coggyria
Beautybush	Kolkwitzia Amabilis
Red Twig Dogwood	Cornus Alba Sibirica

Table 10-14-2 Shrubs for Parking Lot Islands and General Landscaping – Summer Flowering	
Common Name	Scientific Name
Buttonbush	Cephalanthus Occidentalis
American Elderberry	Sambucus Canadensis
Common Ninebark	Physocarpus Opulifolius
Black Chokeberry	Aronia Melanocarpa
Winterberry	Ilex Verticillata
Wild Hydrangea	Hydrangea Aborescens
Virginia Sweetspire	Itea Virginica
Butterfly Bush	Buddleia Davidii
Sumac	Rhus Spp.
Coralberry, Snowberry	Symphoricarpos Spp.

15. Trees and plants identified as “Invasive Species” as defined by the Indiana Department of Natural Resources shall not be planted within the Centennial Village PUD.

Section 11 – Signage

All signs located within the development shall be regulated by Ordinance No. 1679, amending the Town of Munster Zoning Ordinance, Land Development Code Chapter 26, Article VI, Division 10, Signs, conform to the Centennial Village building design architecture and comply with the following standards that may amend Section 26-1053:

1. Prohibited signs:
 - a. Signs that extend above the highest point of a roof line
 - b. Billboards
 - c. Signs painted or mounted upon the exterior side or rear wall of any principal or accessory structure except as otherwise identified in the Design Standards.
 - d. Signs which contain blinking, pulsating, flashing, or moving lighting.
 - e. Neon Lighting Signs
2. Traffic Control Signs including street name, stop signs, parking signs, directional signs and other traffic control signs that are used to implement public safety and wayfinding within the development shall be of an ornamental design similar to the site lighting posts and fixtures, following the decorative style of the Genesis Series by Sternburg Lighting.
3. No sign shall be located to block or obscure the vision of motor vehicle drivers for safe travel through streets and parking areas.
4. No sign shall be erected, located or maintained to prevent access to any door, window, public walkway or fire escape.
5. Materials and color palettes for signs shall follow the approved materials and colors defined in the Town of Munster Ordinance 1679.
6. A sign located on the main entry door or adjacent to the main entry door identifying the business name, hours of operation, address shall not exceed 6 square feet in total area.
7. Each business within multi-tenant buildings will be permitted one principal sign. Such signs may be wall mounted and with a total sign area calculated as 80% of the total building frontage width. For example, a 60-foot frontage width building shall be allowed a maximum sign area of 48 square feet (60-feet x 80%). Signs affixed to the exterior of a building shall be architecturally compatible with the style, composition, materials, colors and details of the building. Box Panel signs shall not be permitted on any building within the development.

The location of tenant signs shall be integrated with the building façade design and not obstruct architectural details and wall signs shall not extend more than 12-inches out from the exterior face of the building.

8. Projecting and Blade Signs extending perpendicular from the wall of a principal structure may be permitted so long as they do not interfere with clear vision to other adjacent business signs and do not interfere with the safe movement of vehicles and pedestrians. The Centennial Village PUD shall evaluate all requests for Projecting and Blade signs on a case by case basis and determine its approval based on the sign's design, materials and number of adjacent projecting banner signs. Projecting and Blade Signs may not extend a distance greater than 4-feet from a principal structure wall, be a minimum of 8-feet from the bottom of the sign to the top of the sidewalk below, may not exceed a total of 15 square feet and shall be counted against the total maximum business signage area.



9. Awning signs are permitted within the Centennial Village PUD following the approved sign design criteria, standards, materials and colors for awning signs defined in the Town of Munster Ordinance 1679.
10. In cases where businesses have rear or side parking lots or adjoins a public street, an additional sign developed to the same restrictions identified in Section 11 – Signage, shall be permitted only on one side or rear of the building.
11. Business signs shall be permitted to be back lighted or front lighted provided the sign illumination does not cause a nuisance to adjoining businesses and properties.
12. A sign bearing the name of a business of the principal tenant occupying space in the rear or upper floors of a building shall be allowed at the principal structure entrance to the business and the area of such sign identifying such business shall not exceed 4 square feet.
13. Free Standing Monument Signs shall be located and permitted to identify the Centennial Village PUD development areas at the locations as defined below:
- a. Lot A – Identifying the development parcel north of 45th Street
 - b. Lot B – Identifying the development parcel south of 45th Street
 - c. Lot E – Identifying the development parcel south of 45th Street and the Lot E use
14. Free Standing Monument Signs shall have a maximum total surface area for any display surface of 100 square feet and a maximum height of 10-feet. The calculation of display surface does not include the surface area of the sign structure that the display surface is mounted.
15. All signs and sign structures shall be maintained in good repair and safe condition. The owner of each sign shall be responsible for the proper maintenance of their respective sign. A sign shall be at all times legible, working and safe for the public.
16. No sign shall be constructed within the development unless the sign information has been reviewed and approved by the Centennial Village PUD developer and the proper permits and approvals have been granted by the Town of Munster.

Section 12 – Refuse & Recycling Management

The handling of refuse and recycling materials generated by the development is an important function for businesses within the Centennial Village PUD. Pick up and removal of these materials from the site shall be scheduled during times that do not conflict with normal hours of operation for the majority of businesses within the development.

All trash, recycling and related material handling equipment shall be stored within the principal structure, within an attached structure accessible from the principal structure or within an un-attached refuse enclosure structure nearby the building it serves. Trash, recycling and related material handling equipment structures shall be totally screened from view from public streets, residential areas and main vehicular and pedestrian routes with the development. Trash and recycling structures and enclosures shall be constructed of the same materials and design style of the principal structure it serves. The structures and enclosures shall be constructed with these materials on 3 sides and provided with an opaque easily operated access door or gate. The Door or gate shall remained closed at all times other than when the material is being picked up and removed.

The location of trash and recycling structure enclosures will be positioned so that the removal equipment can readily access the storage containers and not conflict with service requirements of the site improvements and buildings within the development.

Section 13 – Screening of Loading & Service Areas

The screening requirements to visually enhance loading and service areas to buildings within the development shall utilize architectural screen walls, landscape hedging and architectural fencing.

1. The perimeter views of all external loading and service areas must be screened from public right of ways, residential areas and main vehicular and pedestrian routes with the development except at the points of access.
2. Architectural screen walls and architectural fencing shall be constructed of the same materials and design style of the principal structure it serves. Such walls shall be a minimum of 5-feet in height measured from the finish grade at the base of the wall.
3. Landscape hedges and shrubs used to screen loading and service areas shall maintain a minimum opaqueness of 80% throughout the entire year and shall be a minimum of 5-feet in height at full maturity. Landscaping shall be maintained and any dead plantings shall be promptly replaced.
4. The screening of loading and service areas shall maintain a collective minimum opaqueness of 80% throughout the entire year.
5. Loading and service areas are not permitted to be screen where equipment is required to access the buildings and utility service areas.
6. No outdoor storage of materials shall be permitted.

Section 14 – Site Furniture, Fixtures & Equipment

Site Furniture & Equipment will be incorporated into the final site design of all Buildings. Clear internal pedestrian circulation routes and connections to the Pennsey Greenway Trail will be provided as defined in the Development Plan. Featured locations within development such as key circulation corners shall be highlighted with enhanced design of pedestrian crossings and be provided with other pedestrian amenities as defined in this section.

1. The individual site development plans for all buildings will where applicable include detail design of the listed site amenities:
 - a. Bicycle Racks
 - b. Decorative Trash Receptacles
 - c. Pedestrian Benches
 - d. Decorative Plant Containers
 - e. Fountains
 - f. Public Art
2. Traffic Control Signs including Stop Signs, Traffic Directional Signs and Street Signs will be designed to match the design style of the Site Lighting System Fixtures.
3. The design of Bike Racks, Refuse Dispensers and Pedestrian Benches will be designed to match the design style of the Lighting System Fixtures.



Section 15 – Utility Service

All buildings within the Centennial Village Development shall be serviced with public utilities from the Town of Munster Municipal Utilities and Public Utilities with Franchise service agreements within the Town of Munster. Specifically, the development will be provided with the following utilities and associated utility service providers:

Utility Type	Utility Service Company
Sanitary Sewer	Town of Munster Sanitary Sewer Utility
Storm Water	Town of Munster Storm Water Utility
Water	Town of Munster Water Utility
Electric	NISPCO
Gas	NISPCO
Communication	AT&T
Communication	Comcast

1. Sanitary Sewer Service for the development areas on the south side of 45th Street will be provided by connecting to an existing 10-inch PVC sanitary sewer line located on the south side of Centennial Drive between Calumet Avenue and the Centennial Park parking lot. A new 10-inch sanitary sewer will connect into the existing manhole located on the west side of the Centennial Park parking lot and extend north into the new Centennial Drive.

Sanitary Sewer Service for the development area on the north side of 45th Street will be provided by connecting to an existing gravity sewer located at the southeast corner of Calumet Avenue and the CN Railroad. A new 8-inch sanitary sewer will connect into the existing manhole located on the east side of Calumet Avenue and extend east parallel with the north property line of Lot A.

All Sanitary Sewer Main Lines shall be platted in public utility easements and be dedicated to the Town of Munster Sanitary Sewer Utility for ownership and maintenance. All public utility easements shall be a minimum of 20-feet in width and will be in locations that provide the Utility immediate access for maintenance. All sanitary sewer mains shall be constructed of SDR 26 PVC piping and constructed in accordance with the Munster Sanitary Sewer Utility standard specifications.

Sanitary Sewer Service lines connecting buildings to the Sanitary Sewer Main Lines shall be the owned and maintained by the ownership entity of the building it serves. The sanitary sewer service lines shall be constructed of SDR 26 PVC piping with fittings, manholes and gasket materials meeting the specifications defined in the Munster Sanitary Sewer Utility Use Ordinance.

2. Water Service for domestic and fire service for the development areas on the south side of 45th Street will be provided by connecting to an existing 12-inch water main located on the west side of Calumet Avenue. The development's water distribution system design will provide a water supply loop that connects to the existing 12-inch Calumet Avenue water main with a proposed 12-inch water main at Centennial Drive. The new 12-inch water main will extend along the route of Centennial Drive to 45th Street and further loop back to Calumet Avenue on 45th Street

and connect to an existing 12-inch water main also located on the west side of Calumet Avenue. All proposed water main crossings of Calumet Avenue will be bored under Calumet Avenue. No open cuts of Calumet Avenue will be permitted.

There will be two 8-inch water main inner loops that will extend through the areas west and east of the proposed 12-inch Centennial Drive water main to service the buildings along Calumet Avenue and adjacent to Clay Hole Lake and all buildings located in the 4 quadrants of the development.

All Water Main Lines shall be platted in public utility easements and be dedicated to the Town of Munster Water Utility for ownership and maintenance. All public utility easements shall be a minimum of 20-feet in width and will be in locations that provide the Utility immediate access for maintenance. All water mains shall be constructed of Class 52 ductile iron piping and constructed in accordance with the Munster Water Utility standard specifications. Fire hydrants shall be spaced and located in accordance with Town Ordinance and with the approval of the Munster Fire Department.

Water Service lines connecting buildings to the Water Main Lines shall be the owned and maintained by the ownership entity of the building it serves. The water service lines shall be constructed of Type K copper or Class 52 ductile iron piping with valves, fittings, hydrants and gasket materials meeting the specifications defined in the Munster Water Utility Use Ordinance.

3. Electric and Gas service shall be provided by NIPSCO. Existing Electric Service overhead transmission lines are located on the east and west sides of Calumet Avenue. The specific electric service plan for the development will route electric lines underground to building pad mount transformers. The underground electric route plan will to the extent possible parallel the water and sanitary sewer utility routes. The specific electric service design shall be completed by NIPSCO.

Existing Gas Service mains are located on the east side of Calumet Avenue. The specific gas service plan for the development will route lines underground in a joint trench with the proposed electric lines to building meters. The underground gas route plan will to the extent possible parallel the water and sanitary sewer utility routes. The specific gas service design shall be completed by NIPSCO.

All Electric and Gas Lines shall be platted in public utility easements and be dedicated to the NIPSCO for ownership and maintenance. All NIPSCO utility easements shall be a minimum of 10-feet in width and will be in locations that provide the Utility immediate access for maintenance.

4. Communication service shall be provided by AT&T and Comcast. Existing Communication Service overhead transmission lines are located on the east and west sides of Calumet Avenue. The specific communication service plan for the development will route communication copper and potentially fiber lines underground to building service entry points. The underground communication route plan will to the extent possible parallel the water and sanitary sewer utility routes. The specific communication service design shall be completed by the respective communication utility company.

All Communication Lines shall be platted in public utility easements and be dedicated to the specific utility for ownership and maintenance. All communication utility easements shall be a minimum of 10-feet in width and will be in locations that provide the Utility immediate access for maintenance.

Section 16 – Storm Water Management

Storm Water Runoff from the site shall meet the quantity and quality requirements of the Storm Water Ordinance of the Town of Munster. All storm water shall be permitted to discharge directly into Clay Hole Lake. Clay Hole Lake shall provide the storm water quantity management for all of the Centennial Village PUD development area.

1. The storm water collection system shall be designed following the Munster Storm Water Ordinance and sized to convey the 10-year, 24-hour storm event.
2. The on-site storm water collection system shall be designed to respect the natural drainage patterns of the site and adjacent properties. Inlets, catch basin and manholes shall generally be located to collect storm water along the outer edges of the development so that the development grading plan can match existing adjacent grades.
3. Locations of Inlets, Catch Basins and Manholes will be positioned to avoid main pedestrian walking routes, trash enclosures, and main building entries.
4. Storm Sewer collection system piping shall be made of either Reinforced Concrete Pipe (RCP), Poly Vinyl Chloride (PVC), or High Density Poly Ethylene (HDPE).
5. Building roof drains and footing drains may be connected directly to underground storm sewer system piping to minimize overland runoff to inlets.
6. Clay Hole Lake shall provide the storm water quantity storage requirement of the development. The water's edge of Clay Hole Lake shall be treated and landscaped to provide safe usage of the lake for pedestrians. The storm water management plan for Clay Hole Lake will incorporate the lake as a visual and recreational amenity of the development.
7. The storm water collection system shall be designed with storm water quality structural BMPs to remove suspended solids, oil and gas residuals, snow removal salts, and other pollutants from storm water runoff. The storm water quality system shall be incorporated into the pre and post construction Storm Water Pollution Prevention Plan for the development (SWPPP). The SWPPP construction and post construction period activity shall be strictly adhered and be submitted to the Town of Munster for Storm Water Permitting.
8. A storm water management plan shall be submitted with final site engineering design plans for each building phase of the development. The plan shall include storm water collection system sizing, quantity and quality calculations following the Town of Munster Storm Water Ordinance.
9. An IDEM Rule 5 NOI shall be submitted to the Indiana Department of Environmental Management for all construction related soil disturbing activities.
10. The Centennial Village PUD shall be permitted to modify the positions and locations of building, parking, curbing and other site improvements to accommodate the storm sewer routing for the 45th Street Town of Munster public improvement project. It is anticipated that storm water from the north side of the CN railroad will be routed through the Building A site and extend to

45th Street near the proposed 45th traffic signal. From the signal area, storm sewer routing is anticipated to extend to the south side of 45th Street along Buildings I, M & L to eventually discharge into Clay Hole Lake. Additionally, a storm water pumping station is proposed adjacent to 45th Street between buildings M & L. Any modifications to the Centennial Village PUD due to the 45th Street storm water system shall be permitted to be completed administratively with the Town of Munster's administrative staff.

Section 17 – Subdivision of Land and Site Development Approvals

The Centennial Village PUD consists of 15 building sites. Construction to be completed on all building sites shall submit to the Town of Munster Plan Commission an application for Site Development Plan Approval following Article IX of Chapter 26 of the Town of Munster Land Development Code. The development will complete the appropriate application documentation at the time of each building site development and process the Development Plan Approval through the Munster Plan Commission as outlined in Town Ordinance.

Certain building sites within the Centennial Village PUD may have benefit to execute the subdivision of land in accordance with Article V of Chapter 26 of the Town of Munster Land Development Code. The development will determine on a building site basis how best to hold land ownership interest. The Munster Plan Commission will review and approve all petitions and plats for the subdivision of lots within the Centennial Village PUD.

Appendix 1 – Centennial Village Plat of Survey & Legal Description

Appendix 2 – Preliminary Development Plan

Appendix 3 – Development Plan Set including Preliminary Landscape Plan

Appendix 4 – Project Implementation Phasing Plan